

Darlington Complementary Silicon Power Transistors

TIP140, TIP141, TIP142, (NPN); TIP145, TIP146, TIP147, (PNP)

Designed for general-purpose amplifier and low frequency switching applications.

Features

- High DC Current Gain –
 $\text{Min } h_{FE} = 1000 @ I_C$
 $= 5.0 \text{ A, } V_{CE} = 4 \text{ V}$
- Collector–Emitter Sustaining Voltage – @ 30 mA
 $V_{CEO(sus)} = 60 \text{ Vdc (Min) – TIP140, TIP145}$
 $= 80 \text{ Vdc (Min) – TIP141, TIP146}$
 $= 100 \text{ Vdc (Min) – TIP142, TIP147}$
- Monolithic Construction with Built–In Base–Emitter Shunt Resistor
- These are Pb–Free Devices*

MAXIMUM RATINGS

Symbol	Rating	TIP140 TIP145	TIP141 TIP146	TIP142 TIP147	Unit
V_{CEO}	Collector – Emitter Voltage	60	80	100	Vdc
V_{CB}	Collector – Base Voltage	60	80	100	Vdc
V_{EB}	Emitter – Base Voltage	5.0			Vdc
I_C	Collector Current – Continuous – Peak (Note 1)	10 15			Adc
I_B	Base Current – Continuous	0.5			Adc
P_D	Total Power Dissipation @ $T_C = 25^\circ\text{C}$	125			W
T_J, T_{stg}	Operating and Storage Junction Temperature Range	–65 to +150			$^\circ\text{C}$

Stresses exceeding those listed in the Maximum Ratings table may damage the device. If any of these limits are exceeded, device functionality should not be assumed, damage may occur and reliability may be affected.

THERMAL CHARACTERISTICS

Symbol	Characteristic	Max	Unit
$R_{\theta JC}$	Thermal Resistance, Junction–to–Case	1.0	$^\circ\text{C/W}$
$R_{\theta JA}$	Thermal Resistance, Junction–to–Ambient	35.7	$^\circ\text{C/W}$

1. 5 ms, $\leq 10\%$ Duty Cycle.

*For additional information on our Pb–Free strategy and soldering details, please download the **onsemi** Soldering and Mounting Techniques Reference Manual, [SOLDERRM/D](#).

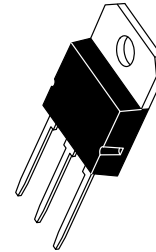

SOT–93 (TO–218)
CASE 340D
STYLE 1

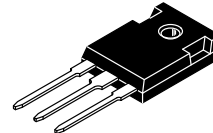

TO–247
CASE 340L
STYLE 3

NOTE: Effective June 2012 this device will be available only in the TO–247 package. Reference FPCN# 16827.

**10 AMPERE
DARLINGTON
COMPLEMENTARY SILICON
POWER TRANSISTORS
60–100 VOLTS, 125 WATTS**

ORDERING INFORMATION

See detailed ordering and shipping information in the package dimensions section on page 8 of this data sheet.

TIP140, TIP141, TIP142, (NPN); TIP145, TIP146, TIP147, (PNP)

MARKING DIAGRAMS

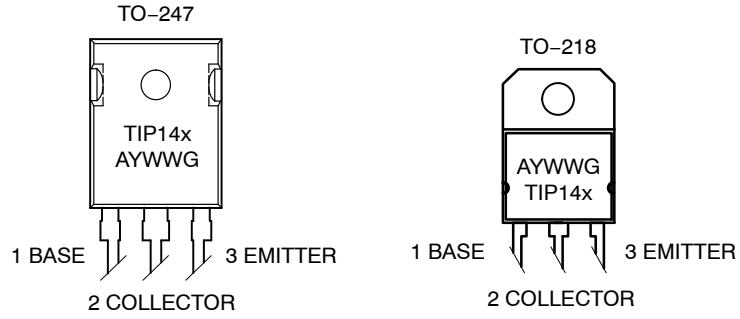

TIP14x = Device Code
 A = Assembly Location
 Y = Year
 WW = Work Week
 G = Pb-Free Package

DARLINGTON SCHEMATICS

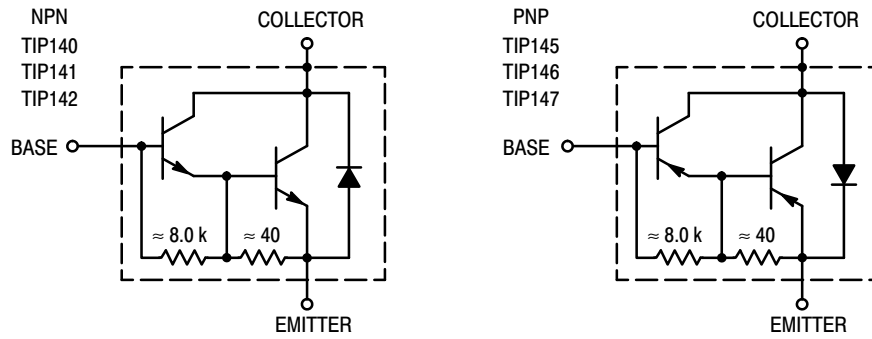

TIP140, TIP141, TIP142, (NPN); TIP145, TIP146, TIP147, (PNP)

ELECTRICAL CHARACTERISTICS ($T_C = 25^\circ\text{C}$ unless otherwise noted)

Symbol	Characteristic	Min	Typ	Max	Unit
OFF CHARACTERISTICS					
$V_{CEO(sus)}$	Collector-Emitter Sustaining Voltage (Note 2) ($I_C = 30\text{ mA}$, $I_B = 0$)	TIP140, TIP145 60 TIP141, TIP146 80 TIP142, TIP147 100	- - -	- - -	Vdc
I_{CEO}	Collector Cutoff Current ($V_{CE} = 30\text{ Vdc}$, $I_B = 0$) ($V_{CE} = 40\text{ Vdc}$, $I_B = 0$) ($V_{CE} = 50\text{ Vdc}$, $I_B = 0$)	TIP140, TIP145 - TIP141, TIP146 - TIP142, TIP147 -	- - -	2.0 2.0 2.0	mA
I_{CBO}	Collector Cutoff Current ($V_{CB} = 60\text{ V}$, $I_E = 0$) ($V_{CB} = 80\text{ V}$, $I_E = 0$) ($V_{CB} = 100\text{ V}$, $I_E = 0$)	TIP140, TIP145 - TIP141, TIP146 - TIP142, TIP147 -	- - -	1.0 1.0 1.0	mA
I_{EBO}	Emitter Cutoff Current ($V_{BE} = 5.0\text{ V}$)	-	-	2.0	mA

ON CHARACTERISTICS (Note 2)

h_{FE}	DC Current Gain ($I_C = 5.0\text{ A}$, $V_{CE} = 4.0\text{ V}$) ($I_C = 10\text{ A}$, $V_{CE} = 4.0\text{ V}$)	1000 500	- -	- -	-
$V_{CE(sat)}$	Collector-Emitter Saturation Voltage ($I_C = 5.0\text{ A}$, $I_B = 10\text{ mA}$) ($I_C = 10\text{ A}$, $I_B = 40\text{ mA}$)	- -	- -	2.0 3.0	Vdc
$V_{BE(sat)}$	Base-Emitter Saturation Voltage ($I_C = 10\text{ A}$, $I_B = 40\text{ mA}$)	-	-	3.5	Vdc
$V_{BE(on)}$	Base-Emitter On Voltage ($I_C = 10\text{ A}$, $V_{CE} = 4.0\text{ Vdc}$)	-	-	3.0	Vdc

SWITCHING CHARACTERISTICS

Resistive Load (See Figure 1)	Resistive Load (See Figure 1)					
t_d	Delay Time	$(V_{CC} = 30\text{ V}$, $I_C = 5.0\text{ A}$, $I_B = 20\text{ mA}$, Duty Cycle $\leq 2.0\%$, $I_{B1} = I_{B2}$, R_C & R_B Varied, $T_J = 25^\circ\text{C}$)	-	0.15	-	μs
t_r	Rise Time		-	0.55	-	μs
t_s	Storage Time		-	2.5	-	μs
t_f	Fall Time		-	2.5	-	μs

2. Pulse Test: Pulse Width = 300 μs , Duty Cycle $\leq 2.0\%$.

TIP140, TIP141, TIP142, (NPN); TIP145, TIP146, TIP147, (PNP)

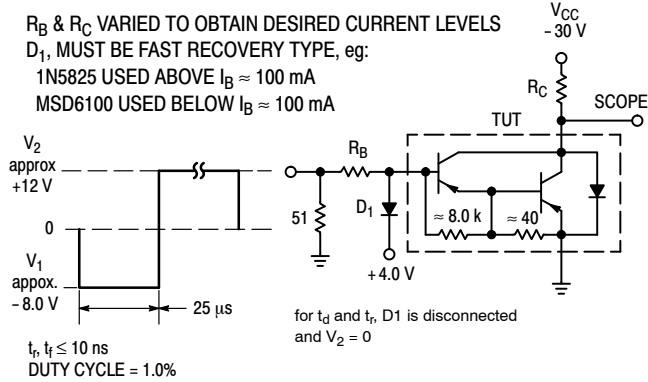

For NPN test circuit reverse diode and voltage polarities.

Figure 1. Switching Times Test Circuit

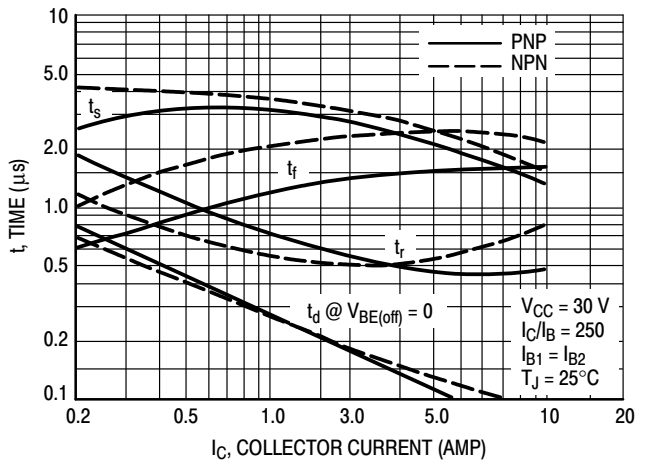

Figure 2. Switching Times

TIP140, TIP141, TIP142, (NPN); TIP145, TIP146, TIP147, (PNP)

TYPICAL CHARACTERISTICS

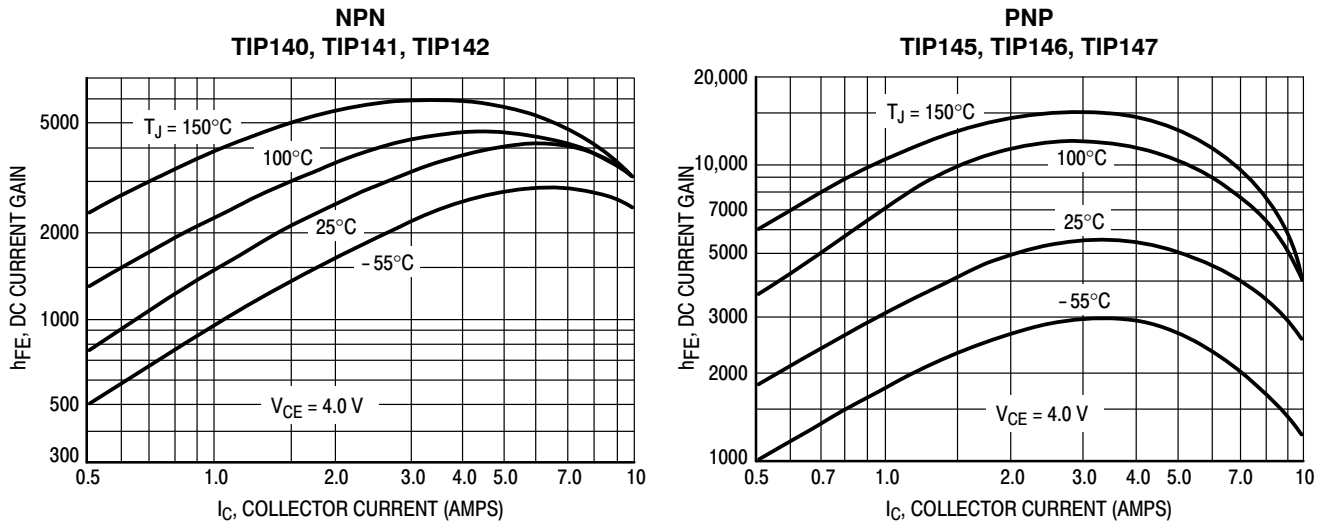

Figure 3. DC Current Gain versus Collector Current

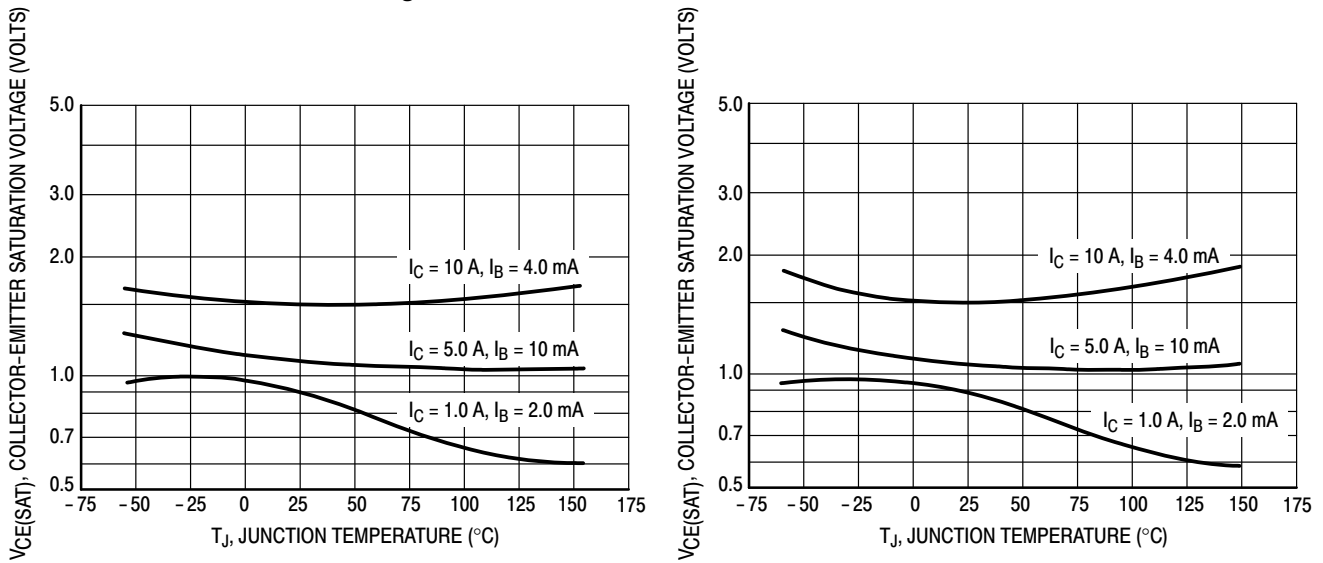

Figure 4. Collector-Emitter Saturation Voltage

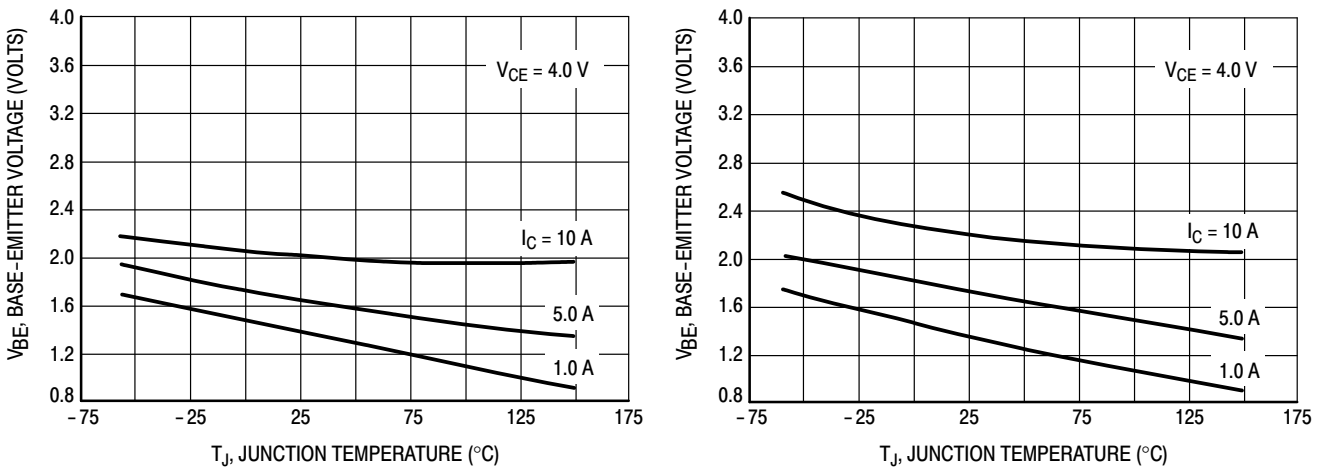

Figure 5. Base-Emitter Voltage

TIP140, TIP141, TIP142, (NPN); TIP145, TIP146, TIP147, (PNP)

ACTIVE-REGION SAFE OPERATING AREA

There are two limitations on the power handling ability of a transistor: average junction temperature and second breakdown. Safe operating area curves indicate $I_C - V_{CE}$ limits of the transistor that must be observed for reliable operation; i.e., the transistor must not be subjected to greater dissipation than the curves indicate.

The data of Figure 6 is based on $T_{J(pk)} = 150^\circ\text{C}$; T_C is variable depending on conditions. At high case temperatures, thermal limitations will reduce the power that can be handled to values less than the limitations imposed by second breakdown.

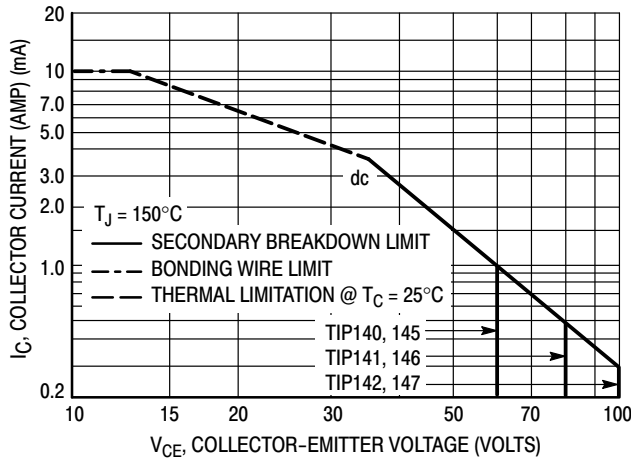

Figure 6. Active-Region Safe Operating Area

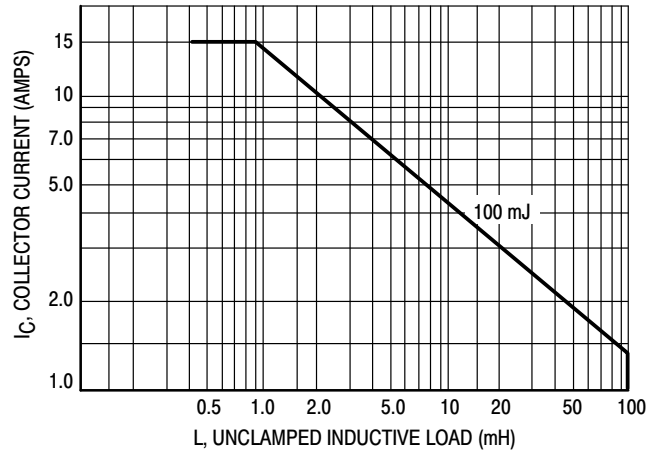
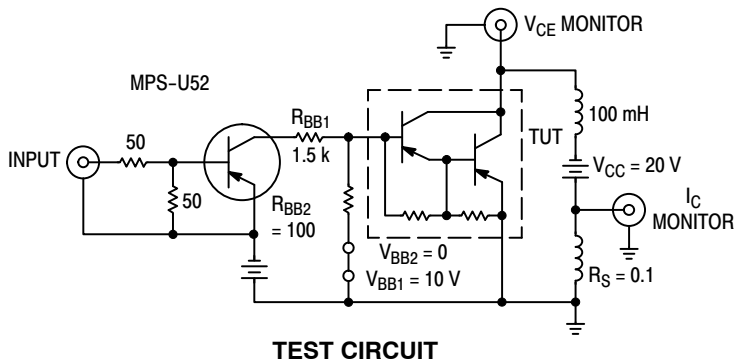
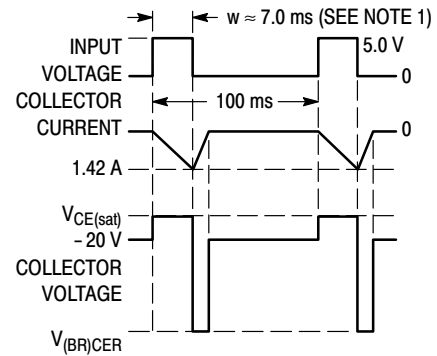

Figure 7. Unclamped Inductive Load



TEST CIRCUIT

NOTE 1: Input pulse width is increased until $I_{CM} = 1.42\text{ A}$.
NOTE 2: For NPN test circuit reverse polarities.



VOLTAGE AND CURRENT WAVEFORMS

Figure 8. Inductive Load

TIP140, TIP141, TIP142, (NPN); TIP145, TIP146, TIP147, (PNP)

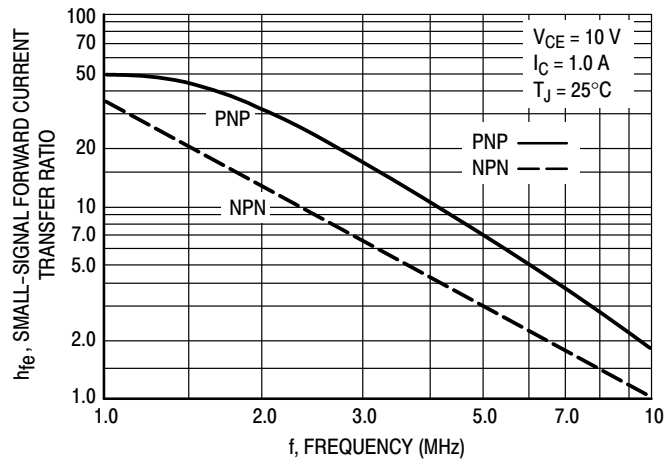

Figure 9. Magnitude of Common Emitter Small-Signal Short-Circuit Forward Current Transfer Ratio

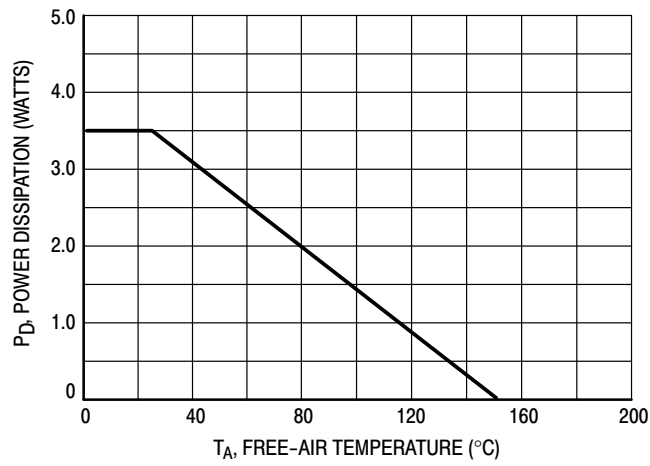

Figure 10. Free-Air Temperature Power Derating

TIP140, TIP141, TIP142, (NPN); TIP145, TIP146, TIP147, (PNP)

ORDERING INFORMATION

Device	Package	Shipping
TIP140G	SOT-93 (TO-218) (Pb-Free)	30 Units / Rail
TIP141G	SOT-93 (TO-218) (Pb-Free)	30 Units / Rail
TIP142G	SOT-93 (TO-218) (Pb-Free)	30 Units / Rail
TIP145G	SOT-93 (TO-218) (Pb-Free)	30 Units / Rail
TIP146G	SOT-93 (TO-218) (Pb-Free)	30 Units / Rail
TIP147G	SOT-93 (TO-218) (Pb-Free)	30 Units / Rail
TIP140G	TO-247 (Pb-Free)	30 Units / Rail
TIP141G	TO-247 (Pb-Free)	30 Units / Rail
TIP142G	TO-247 (Pb-Free)	30 Units / Rail
TIP145G	TO-247 (Pb-Free)	30 Units / Rail
TIP146G	TO-247 (Pb-Free)	30 Units / Rail
TIP147G	TO-247 (Pb-Free)	30 Units / Rail

SOT-93 (TO-218)
CASE 340D-02
ISSUE E

DATE 03 JAN 2002

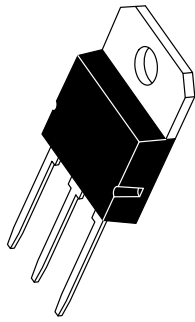

SCALE 1:1

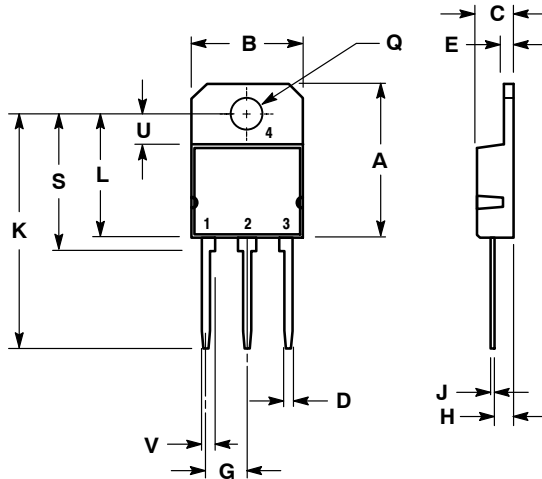

STYLE 1:
PIN 1. BASE
2. COLLECTOR
3. EMITTER
4. COLLECTOR

STYLE 2:
PIN 1. ANODE
2. CATHODE
3. ANODE
4. CATHODE

NOTES:
1. DIMENSIONING AND TOLERANCING PER ANSI Y14.5M, 1982.
2. CONTROLLING DIMENSION: MILLIMETER.

DIM	MILLIMETERS		INCHES	
	MIN	MAX	MIN	MAX
A	---	20.35	---	0.801
B	14.70	15.20	0.579	0.598
C	4.70	4.90	0.185	0.193
D	1.10	1.30	0.043	0.051
E	1.17	1.37	0.046	0.054
G	5.40	5.55	0.213	0.219
H	2.00	3.00	0.079	0.118
J	0.50	0.78	0.020	0.031
K	31.00 REF		1.220 REF	
L	---	16.20	---	0.638
Q	4.00	4.10	0.158	0.161
S	17.80	18.20	0.701	0.717
U	4.00 REF		0.157 REF	
V	1.75 REF		0.069	

GENERIC MARKING DIAGRAM*



A = Assembly Location
Y = Year
WW = Work Week
XXXXX = Device Code

*This information is generic. Please refer to device data sheet for actual part marking. Pb-Free indicator, "G" or microdot "▪", may or may not be present. Some products may not follow the Generic Marking.

DOCUMENT NUMBER:	98ASB42643B	Electronic versions are uncontrolled except when accessed directly from the Document Repository. Printed versions are uncontrolled except when stamped "CONTROLLED COPY" in red.
DESCRIPTION:	SOT-93 (TO-218)	PAGE 1 OF 1

onsemi and ONSEMI are trademarks of Semiconductor Components Industries, LLC dba onsemi or its subsidiaries in the United States and/or other countries. onsemi reserves the right to make changes without further notice to any products herein. onsemi makes no warranty, representation or guarantee regarding the suitability of its products for any particular purpose, nor does onsemi assume any liability arising out of the application or use of any product or circuit, and specifically disclaims any and all liability, including without limitation special, consequential or incidental damages. onsemi does not convey any license under its patent rights nor the rights of others.

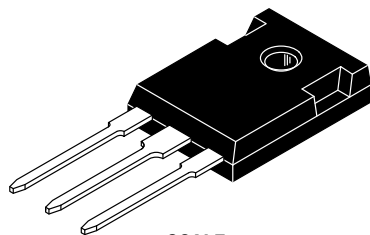

TO-247
CASE 340L
ISSUE G

DATE 06 OCT 2021

SCALE 1:1

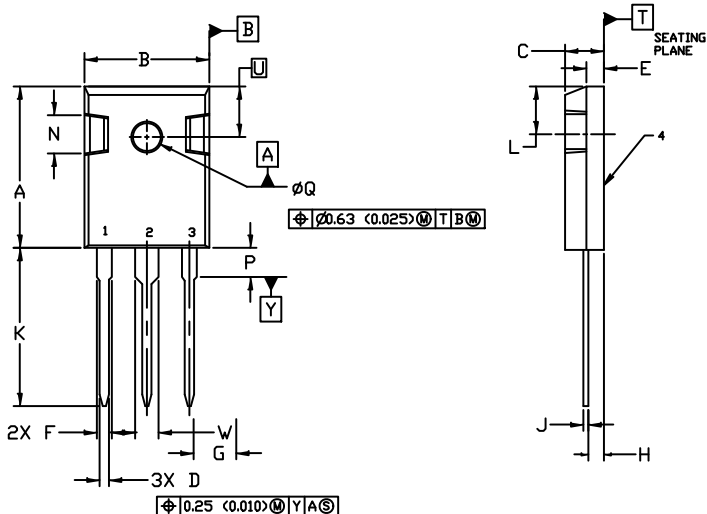

NOTES:

1. DIMENSIONING AND TOLERANCING PER ASME Y14.5M, 1982.
2. CONTROLLING DIMENSION: MILLIMETER

DIM	MILLIMETERS		INCHES	
	MIN.	MAX.	MIN.	MAX.
A	20.32	21.08	0.800	0.830
B	15.75	16.26	0.620	0.640
C	4.70	5.30	0.185	0.209
D	1.00	1.40	0.040	0.055
E	1.90	2.60	0.075	0.102
F	1.65	2.13	0.065	0.084
G	5.45 BSC		0.215 BSC	
H	1.50	2.49	0.059	0.098
J	0.40	0.80	0.016	0.031
K	19.81	20.83	0.780	0.820
L	5.40	6.20	0.212	0.244
N	4.32	5.49	0.170	0.216
P	----	4.50	----	0.177
Q	3.55	3.65	0.140	0.144
U	6.15 BSC		0.242 BSC	
W	2.87	3.12	0.113	0.123

GENERIC
MARKING DIAGRAM*

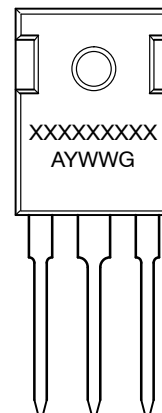

- | | | | |
|--|--|--|--|
| <p>STYLE 1:
PIN 1. GATE
2. DRAIN
3. SOURCE
4. DRAIN</p> | <p>STYLE 2:
PIN 1. ANODE
2. CATHODE (S)
3. ANODE 2
4. CATHODES (S)</p> | <p>STYLE 3:
PIN 1. BASE
2. COLLECTOR
3. EMITTER
4. COLLECTOR</p> | <p>STYLE 4:
PIN 1. GATE
2. COLLECTOR
3. EMITTER
4. COLLECTOR</p> |
| <p>STYLE 5:
PIN 1. CATHODE
2. ANODE
3. GATE
4. ANODE</p> | <p>STYLE 6:
PIN 1. MAIN TERMINAL 1
2. MAIN TERMINAL 2
3. GATE
4. MAIN TERMINAL 2</p> | | |

- XXXXX = Specific Device Code
A = Assembly Location
Y = Year
WW = Work Week
G = Pb-Free Package

*This information is generic. Please refer to device data sheet for actual part marking. Pb-Free indicator, "G" or microdot "•", may or may not be present. Some products may not follow the Generic Marking.

DOCUMENT NUMBER:	98ASB15080C	Electronic versions are uncontrolled except when accessed directly from the Document Repository. Printed versions are uncontrolled except when stamped "CONTROLLED COPY" in red.
DESCRIPTION:	TO-247	PAGE 1 OF 1

onsemi and onsemi are trademarks of Semiconductor Components Industries, LLC dba onsemi or its subsidiaries in the United States and/or other countries. onsemi reserves the right to make changes without further notice to any products herein. onsemi makes no warranty, representation or guarantee regarding the suitability of its products for any particular purpose, nor does onsemi assume any liability arising out of the application or use of any product or circuit, and specifically disclaims any and all liability, including without limitation special, consequential or incidental damages. onsemi does not convey any license under its patent rights nor the rights of others.

onsemi, **Onsemi**, and other names, marks, and brands are registered and/or common law trademarks of Semiconductor Components Industries, LLC dba "**onsemi**" or its affiliates and/or subsidiaries in the United States and/or other countries. **onsemi** owns the rights to a number of patents, trademarks, copyrights, trade secrets, and other intellectual property. A listing of **onsemi**'s product/patent coverage may be accessed at www.onsemi.com/site/pdf/Patent-Marking.pdf. **onsemi** reserves the right to make changes at any time to any products or information herein, without notice. The information herein is provided "as-is" and **onsemi** makes no warranty, representation or guarantee regarding the accuracy of the information, product features, availability, functionality, or suitability of its products for any particular purpose, nor does **onsemi** assume any liability arising out of the application or use of any product or circuit, and specifically disclaims any and all liability, including without limitation special, consequential or incidental damages. Buyer is responsible for its products and applications using **onsemi** products, including compliance with all laws, regulations and safety requirements or standards, regardless of any support or applications information provided by **onsemi**. "Typical" parameters which may be provided in **onsemi** data sheets and/or specifications can and do vary in different applications and actual performance may vary over time. All operating parameters, including "Typicals" must be validated for each customer application by customer's technical experts. **onsemi** does not convey any license under any of its intellectual property rights nor the rights of others. **onsemi** products are not designed, intended, or authorized for use as a critical component in life support systems or any FDA Class 3 medical devices or medical devices with a same or similar classification in a foreign jurisdiction or any devices intended for implantation in the human body. Should Buyer purchase or use **onsemi** products for any such unintended or unauthorized application, Buyer shall indemnify and hold **onsemi** and its officers, employees, subsidiaries, affiliates, and distributors harmless against all claims, costs, damages, and expenses, and reasonable attorney fees arising out of, directly or indirectly, any claim of personal injury or death associated with such unintended or unauthorized use, even if such claim alleges that **onsemi** was negligent regarding the design or manufacture of the part. **onsemi** is an Equal Opportunity/Affirmative Action Employer. This literature is subject to all applicable copyright laws and is not for resale in any manner.

ADDITIONAL INFORMATION

TECHNICAL PUBLICATIONS:

Technical Library: www.onsemi.com/design/resources/technical-documentation
onsemi Website: www.onsemi.com

ONLINE SUPPORT: www.onsemi.com/support

For additional information, please contact your local Sales Representative at www.onsemi.com/support/sales